

i-mop[®] XL Pro

Auto scrubber for floor surfaces

User manual



[i-team Professional b.v.](#)

[Hoppenkuil 27b, 5626 DD Eindhoven, The Netherlands](#)

[Telephone: 1300 799 312](#)

[Email: service@capitalequipment.com.au](mailto:service@capitalequipment.com.au)

[Internet: capitalequipment.com.au](http://capitalequipment.com.au)





FASTER:

Cleans 10 times faster than conventional wet mopping, backed-up by cleaning capacity of up to 1800 m² per hour.



CLEANER:

Powerful twin counter-rotating 350 RPM brushes for soil removal validated by ATP test data, reflecting up to 90% cleaner surfaces.



GREENER:

Makes every ounce of chemical and every drop of water count. Proven to reduce environmental impact by over 75%.



SAFER:

Floors that dry almost instantly reduce slip and fall hazards, validated by standardized slip test readings of 120 or less. The antibacterial tanks on the i-mop[®] reduces the odors coming from the recovery tank and protects operators who handle the tanks every day. Bacterial reduction in contact with the tank wall has been certified and tested at $\geq 99.99\%$ efficacy.



BETTER FOR EVERYONE:

Changes the experience of cleaning, and brings energy, pride and positive morale to the facility... not to mention a cleaner and healthier environment.

Original user manual, written in the English Language

Future Cleaning Technologies B.V.

Hoppenkuil 27b, 5626 DD Eindhoven, The Netherlands

Telephone: +31402662400

Email: hello@i-teamglobal.com

Internet: www.i-teamglobal.com

Model: i-mop[®] XL Pro

Date: 04-05-2022

Product code:

Version: 3.0

Model year: 2022



Preface

Thank you for choosing the i-mop® XL Pro, the industrial auto scrubber that cleans faster, cleaner, safer, greener, and is better for everyone. The i-mop XL Pro's compact design allows you to clean right to the edge and under obstacles, minimizing manual scrubbing. The battery operated i-mop XL Pro is equipped with two counter-rotating brushes that provide a deep scrub and a great cleaning result. The i-mop XL Pro significantly reduces the amount of water and chemicals needed which leads to a greener result. It also reduces the risk of slippery floors. The i-mop XL Pro is coated to withstand abrasive chemicals, this means it can be used at facilities like swimming pools and beach areas.

Antibacterial tanks

The tanks on the i-mop use an antibacterial mix-in to make the plastic safer from the inside and outside. Because it is mixed into the plastic, the effect lasts the lifetime of the tank. The reduction of bacteria reduces odors coming from the recovery tank and protects operators who handle the tank every day. Bacterial reduction in contact with the tank wall is certified and tested at $\geq 99.99\%$ efficacy.

i-dose®

With i-dose we introduce pods that contain a super concentrated, eco-friendly, cleaning formula for the i-mop. Just pop the pod and wait for the liquid to drop in the water. Every pod contains exactly enough detergent for one i-dose solution tank. The i-mop comes with a standard i-dose pod holder and recycle bin for empty pods.

Lift kit

Sometimes detergents or disinfectants need some dwell time when you're cleaning the floor. And now you can easily give them that time. The lift kit makes it possible to lift the squeegee up with the flick of a switch.

Drive and park support

Drive support allows the operator to use the i-mop with up to 2,75 kg less weight on the handle for easier turning and mopping. You can adjust the handle to 2 different heights so it can be used by people of varying postures. Use your foot to engage and disengage the drive support and get going.

Park support allows you to park the i-mop in a standing position for 10 minutes without lifting the deck. Simply engage or disengage with your foot.

i-link®

You can connect your cleaning equipment to i-link, the cloud-based management system. The i-mop XL Pro has a small integrated transmitter, already connected to the i-link cloud. This transmitter will send usage information, battery levels, and even the location of the machine to the i-link cloud every day. It's also possible to set rules for notifications (e.g. reminders for maintenance after X hours of use) and to troubleshoot an issue with the machine to your i-partner.



Please read this manual carefully for important information and operating instructions before using the i-mop® XL Pro. Save this manual for future reference. This i-mop XL Pro will provide excellent performance. The best results are obtained when the i-mop XL Pro is:

- Regularly maintained per the i-mop XL Pro preventive maintenance instructions in this manual.
- Operated with reasonable care and caution.
- Maintained with manufacturer-supplied parts.

When this manual refers to “the manufacturer”, this means **Future Cleaning Technologies B.V.**, an affiliate company of i-team in Eindhoven, the Netherlands. When this manual mentions “the partner”, this refers to your local i-team resell and support service partner.

Purpose of the user manual

The purpose of the user manual is to provide the user with information in such a way that during the life of the i-mop XL Pro, the machine is used correctly, efficiently and safely, even in the event of reasonably foreseeable misuse, as described in section 1.2 of this manual.

The user manual contains instructions regarding:

- Personal operator safety
- Intended and non-intended use of the i-mop XL Pro
- Instructions for daily use
- Maintenance instructions
- Storage conditions
- Disposal of the i-mop XL Pro

These instructions must be considered to avoid risks that could lead to physical and/or material damage.

Target audience

This user manual is intended for operators of the i-mop XL Pro and their supervisors, as well as partners and importers.







Operators of the i-mop XL Pro

The i-mop XL Pro may only be operated by a person who has correctly read and understood the instructions in this manual or is trained by an experienced operator who has read and understood the instructions in this manual.



Reading guide

The following symbols and terms are used throughout this manual to alert the reader to safety issues and important information:

Symbol	Term	Explanation
	WARNING	Indicates a hazardous situation which, if the safety instructions are not followed, can lead to injuries of the operator or bystanders and light or moderate damage to the product or the environment.
	CAUTION	Indicates a hazardous situation which, if the safety instructions are not followed, can lead to light and/or moderate damage to the product or the environment.
	ATTENTION	Indicates a liability situation, where the manufacturer or its partners and affiliates cannot be held accountable for damages caused by non-compliance.
	STRONG MAGNET	Indicates that the machine contains strong magnets. These can cause pacemakers to stop working or cause electronic data to be damaged, such as information stored on access passes.
	PACEMAKER	Indicates that the operators and maintenance crew wearing pacemakers should keep a minimal distance of 6 in / 15 cm. In this specific case operators may not use the machine as a backpack.
	BATTERIES	Indicates a battery-operated machine, batteries must be charged according to the instructions in the separate class I battery charger user manual. Batteries must be disposed of according to your local laws and regulations.
	SLIPPERY SURFACE	Indicates that the machine can cause floors to become slippery. In the workplace, it is advised to place slippery surface signs in these areas.



Content

Preface	3
Purpose of the user manual	4
Target audience	4
Operators of the i-mop XL Pro	4
Reading guide	5
1 Introduction	9
1.1 Intended use of the product	9
1.2 Non-intended use of the product	10
1.3 Lifespan	10
1.4 Modifications	10
1.5 Specifications	11
1.6 Warranty	12
1.7 Identification	12
2 Description	13
3 Safety	14
3.1 General safety instructions	14
3.1.1 Sweep before scrub	14
3.1.2 Brush condition	14
3.1.3 Machine orientation	14
3.1.4 Antibacterial tanks	14
3.1.5 Strong magnets	14
3.1.6 Batteries	14
3.2 Risks during operation	15
3.2.1 Dress safely	15
3.2.2 Mark the job site	15
3.2.3 Careful when parking	15
3.2.4 Careful using drive support	15
3.3 Risks after operation	15
3.3.1 Remove battery packs	15
3.3.2 Machine orientation	15
3.3.3 Careful when storing	15
4 Transport and storage	16
4.1 General	16
4.2 Store position	16
4.3 Transport outside	17
4.4 Transport in a vehicle	18
5 Assembly and installation	19
5.1 Unboxing	19



5.2	Assembly	20
5.2.1	Charging the batteries.....	20
5.2.2	Attaching the brushes	20
5.2.3	Attaching the squeegee.....	21
5.2.4	Installing the recovery tank.....	21
5.2.5	Installing the cleaning solution tank.....	22
5.2.6	Attaching the recycle bin.....	22
5.2.7	Installing the drive support.....	23
6	Operation	24
6.1	Before you start.....	24
6.1.1	Inserting the batteries.....	24
6.1.2	Filling the cleaning solution tank	25
6.2	Operation procedure	26
6.2.1	Walking to the job site	26
6.2.2	At the job site	27
6.2.3	Drive support.....	30
6.2.4	Park support.....	30
6.2.5	Lifter kit.....	31
6.2.6	ECO mode	31
6.2.7	Water level warning indicator	32
6.2.8	Turning off the i-mop® XL pro	32
6.2.9	Emptying tanks.....	32
6.3	Cleaning and storage	33
6.3.1	Flushing the system	33
6.3.2	the tanks	34
6.3.3	Removing battery packs.....	34
6.3.4	Checking the brushes and squeegee	34
6.3.5	Store in an upright position	35
7	Maintenance	36
7.1	Brush replacement.....	36
7.2	Squeegee replacement.....	37
7.2.1	Detaching the squeegee.....	37
7.2.2	Flipping/replacing the squeegee blade	37
7.2.3	Attaching the squeegee.....	38
7.3	Replacing the vacuum hose	38
7.4	Recommended additional cleaning	39
7.5	Recommended service time	39
7.6	Accessories	39
8	Troubleshooting	40
8.1	Report problem via i-link®	40
9	Decommissioning and disposal.....	41
10	Attachments	42
10.1	CE Certificate.....	42



10.2	Specifications	43
10.3	The i-Story	44



1 Introduction

The i-mop® XL Pro is a safe, user-friendly machine. This manual helps you to get started and explains the operation and maintenance procedure. You will be pleasantly surprised by the fast and effective use of the battery operated i-mop XL Pro. The batteries used in the i-mop XL Pro are the same as the ones in a variety of battery powered i-team products. The batteries must be fully charged before use. Please see the user manual of the class I battery charger for correct procedure.

This manual is intended for those who work with the i-mop XL Pro and/or perform daily maintenance. The manual must be read fully before the first actions. This manual describes the correct method of use, safety measures, maintenance and transport.

The manufacturer continuously improves all their products based on user experience and feedback. Any deviations between the texts and/or images from the manual and your i-mop XL Pro can therefore arise from the difference in model or from possible changes due to continuous development and innovation.

1.1 Intended use of the product

The i-mop XL Pro is a specialized machine for scrubbing floor surfaces. You can use any type of water-based scrubbing detergent.

The fluid tank, brushes and squeegee come in HACCP color coded versions (blue, green, red, yellow and orange). All three items can be easily replaced. This allows you to use different cleaning solutions, for instance; when you move from the food preparing area to the restaurant. Make sure that the color code for the fluid tank, brush and squeegee **ALWAYS** match each other.



Figure 1



1.2 Non-intended use of the product



WARNING

Non-intended use can have consequences for the safety of operators and bystanders and will void the warranty on the product.

- **NEVER** operate the i-mop® XL Pro near flammable dusts, liquids or vapors.
- **NEVER** operate the i-mop XL Pro when flammable or poisonous liquids like gasoline, oil, acids, or other volatile substances are on the floor.
- **DO NOT** fill the i-mop XL Pro with any flammable detergent. **ONLY** use the water-based cleaning solutions.
- **DO NOT** use water that exceeds 113 °F / 45 °C. Using water warmer than this temperature will void the tank warranty.
- **DO NOT** use cleaning solutions with a pH level below 3 or above 11 in order to prevent damage to sensitive components.
- **DO NOT** use the i-mop XL Pro outdoors or on uneven surfaces.
- **DO NOT** operate this i-mop XL Pro over electrical floor outlets in order to avoid electrical shock.
- **NO RIDERS!** Do not carry passengers on top of the i-mop XL Pro.
- **DO NOT** use the i-mop XL Pro as stepladder or platform.
- **DO NOT** store the i-mop XL Pro outside in order to avoid damage to electronic components.
- **ONLY** use manufacturer-supplied parts for maintenance.
- **KEEP AWAY** from children! The i-mop XL Pro is a professional cleaning machine to be used by trained adults only.

1.3 Lifespan

Each i-mop XL Pro is guaranteed to operate for at least 2000 hours. The wear on brushes and squeegee heavily depends on the roughness of the surface. They need to be checked regularly.



CAUTION

To ensure proper and safe operation throughout the life of the i-mop XL Pro, the machine must be checked by an authorized i-team partner every 500 hours.

1.4 Modifications

It is not permitted to make modifications to the design of the i-mop XL Pro without consultation and permission from the manufacturer. This affects the warranty, see section 1.6 of this manual.



1.5 Specifications

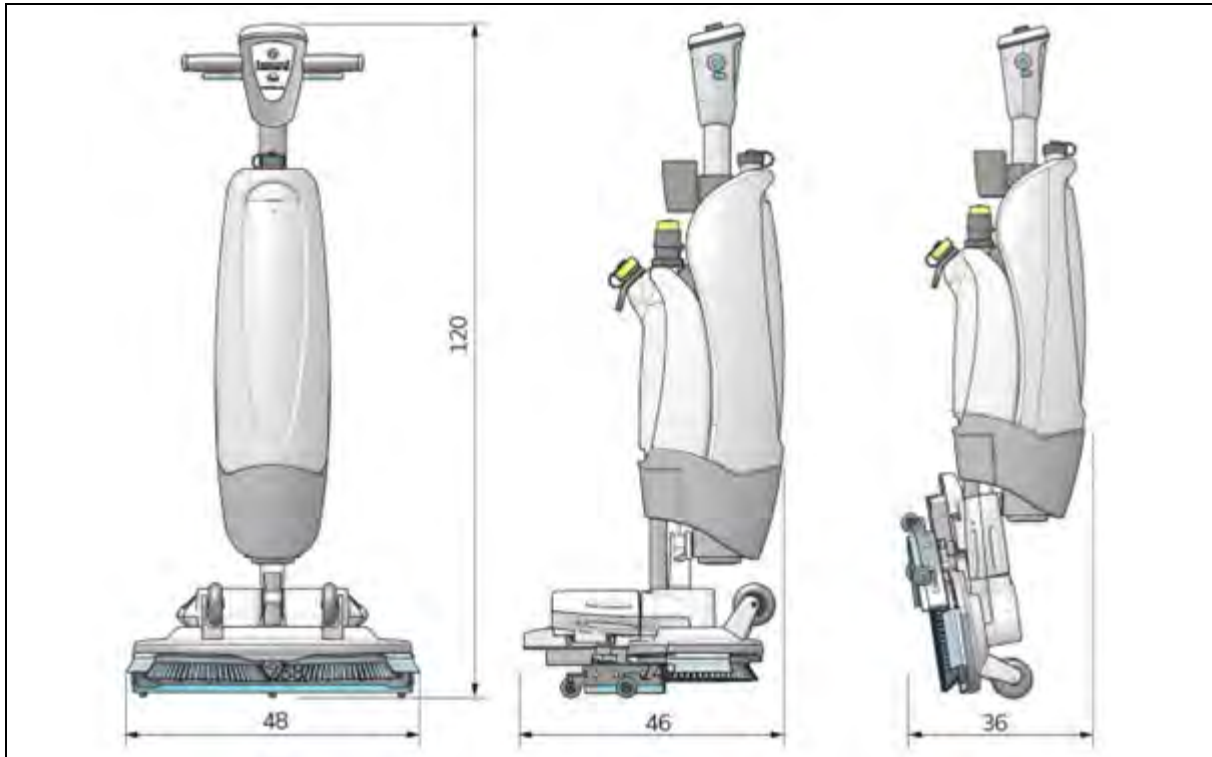

Figure 2

Product size:	120 x 48 x 46 cm
Product size in store position:	120 x 48 x 36 cm
Weight (including batteries):	22.5 kg
Li-on battery:	DC (25.2V, 14Ah, 353Wh)
Battery capacity:	2 batteries
Operation time of batteries:	90 min
Brush pressure:	31.5 gr/cm ²
Brush speed:	350 RPM
Detergent tank capacity:	4 L
Recovery tank capacity:	6 L / 4 L recommended max
Vibration:	Amplitude (mm): <0.4442 Velocity (m/s): <0.008 Acceleration (m/s ²): 0.943
Noise level (1m):	64.9 Db
Theoretical performance:	Up to 1800 m ² per hour
Practical performance:	1000 - 1300 m ² per hour
Scrub deck anti-corrosion coating:	YES
Castor wheels:	YES
Power cut off at store position:	YES
Angle power cut off:	YES < 32°
Floating ball for recovery tank:	YES
Hour counter:	YES via i-link



1.6 Warranty

The i-mop® XL Pro should be used as intended and described in this manual. Using the i-mop XL Pro outside will void the warranty on the product.

1.7 Identification

The ID tag, containing a serial number and production number, can be found on the bar behind the wastewater tank.

- Serial number (Figure 3, pos. 1).
- Production day (Figure 3, pos. 2).
- Production year (Figure 3, pos. 3).

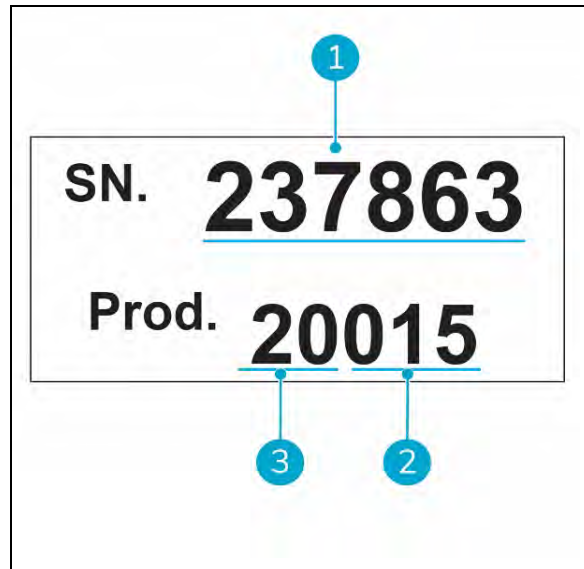

Figure 3



2 Description

The compact i-mop® XL Pro consists of two main parts:

- The body that contains the motor, cleaning solution tank, recovery tanks, handle with triggers and control panel.
- The scrub deck that contains the brushes and squeegee.

The i-mop XL Pro can be folded into a store position; this is recommended for storage.

The i-mop XL Pro consists of:

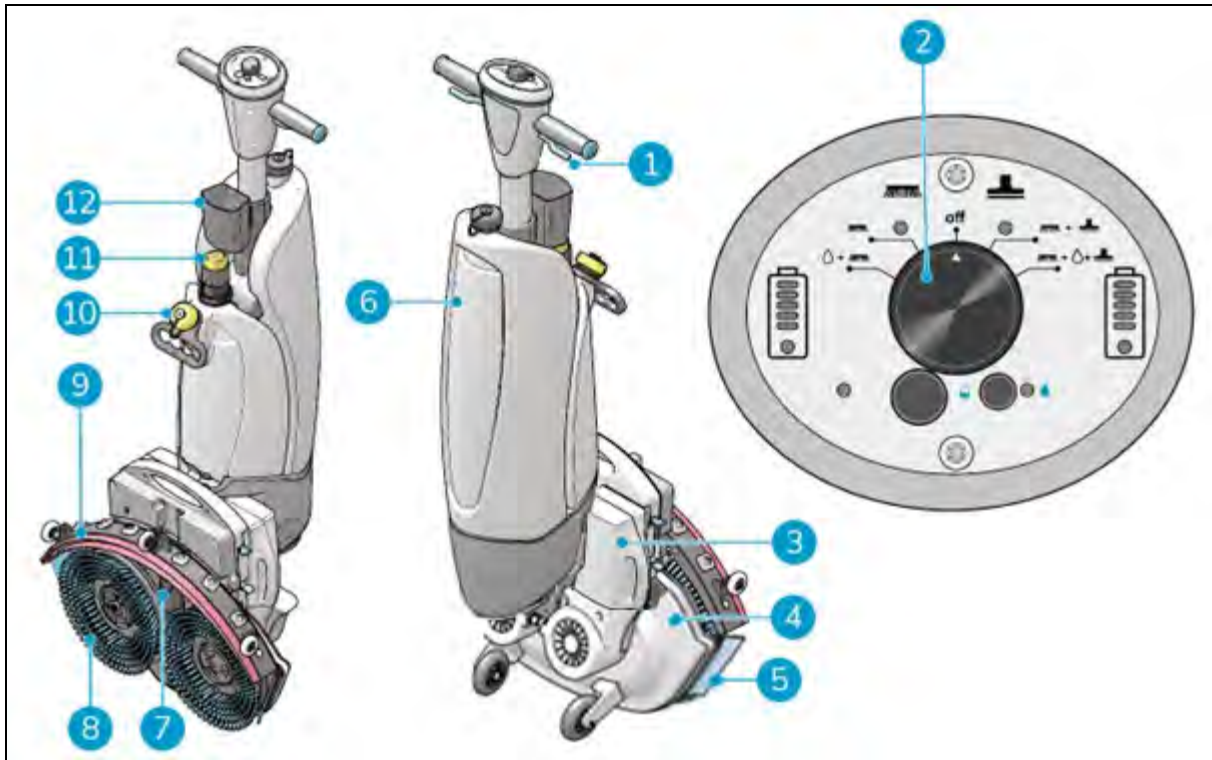

Figure 4

Legend

- | | |
|------------------|---------------------|
| 1. Trigger | 7. Vacuum hose |
| 2. Control panel | 8. Rotating brushes |
| 3. Batteries | 9. Squeegee |
| 4. Scrub deck | 10. Solution tank |
| 5. Splash guard | 11. I-dose |
| 6. Recovery tank | 12. Waste bin |



3 Safety

Safety comes first. Therefore, please take your time to read and understand these safety instructions. Improper use can cause harm or void the manufacturer's warranty.

3.1 General safety instructions

3.1.1 Sweep before scrub

Remove objects from the floor that can be propelled by the rotating brushes.

3.1.2 Brush condition

Make sure to check the condition of the brush before use. Change the brush only when the machine is turned off in a store position.

3.1.3 Machine orientation

Always keep the body of the i-mop® XL Pro in an upright position when inserting cleaning fluid or batteries.

3.1.4 Antibacterial tanks

Always keep the antibacterial tanks of the i-mop out of direct sunlight. This can cause discoloration.

3.1.5 Strong magnets



CAUTION

Please be aware of the integrated magnets that hold the fluid tank in place.



WARNING

Operators and maintenance crew wearing pacemakers should keep a minimal distance of 6 in / 15 cm.

3.1.6 Batteries

Always use the automatic battery charger provided by the manufacturer.



CAUTION

During normal operation, the 24 V batteries cause no safety hazard on their own. Please adhere to the following safety instructions regarding the batteries:

- Do not crush, pierce or damage in any way.
- Do not heat or incinerate.
- Do not short-circuit.
- Do not dismantle.
- Keep dry.
- Only charge between 5 °C~40 °C / 41 °F~104 °F.
- Only use between 5 °C~45 °C / 41 °F~113 °F.



3.2 Risks during operation

3.2.1 Dress safely

Do not wear a necktie, scarf, or any loose or dangling clothing or jewelry while operating the i-mop® XL Pro. These can tangle in rotating parts, causing serious injury or death.

3.2.2 Mark the job site

The i-mop XL Pro is designed to leave a dry floor without slippery patches, no additional drying is required. When running the i-mop XL Pro with the vacuum function OFF please mark the job site with a wet floor marker.



CAUTION

Marking the jobsite with a wet floor marker is not required when using the vacuum function of the i-mop XL Pro, unless this is a mandatory work safety requirement by local law. When unsure mark the job site to warn passersby.

3.2.3 Careful when parking

Do not park the i-mop XL Pro on ramps or slopes. Always park the i-mop XL Pro on a level, hard surface. Do not park the i-mop XL Pro using the drive support **ONLY**, the device may fall sideways. The i-mop XL Pro should only be parked either with the park support or by lifting the deck into store position.

3.2.4 Careful using drive support

Do not park the i-mop XL Pro using the drive support, the device may fall sideways.

3.3 Risks after operation

3.3.1 Remove battery packs

It is best practice to remove the batteries before executing any cleaning, maintenance task or before storage.

3.3.2 Machine orientation

Always keep the body of the i-mop XL Pro in an upright (store) position when replacing brushes or squeegee.

3.3.3 Careful when storing

Do not store the i-mop XL Pro on ramps or slopes. Always store the i-mop XL Pro on a level, hard surface. Do not store the i-mop XL Pro in park position.



4 Transport and storage

4.1 General



CAUTION

Always keep the body of the i-mop® XL Pro in an upright position when filling the cleaning solution tank or inserting the batteries.

Before storage or transport, drain the machine and remove the batteries after each use.

4.2 Store position



CAUTION

Do not put the i-mop XL Pro in store position while the drive support and the park support are active. First deactivate the drive support and the park support.

The store position is the upright vertical position for storage and maintenance tasks.

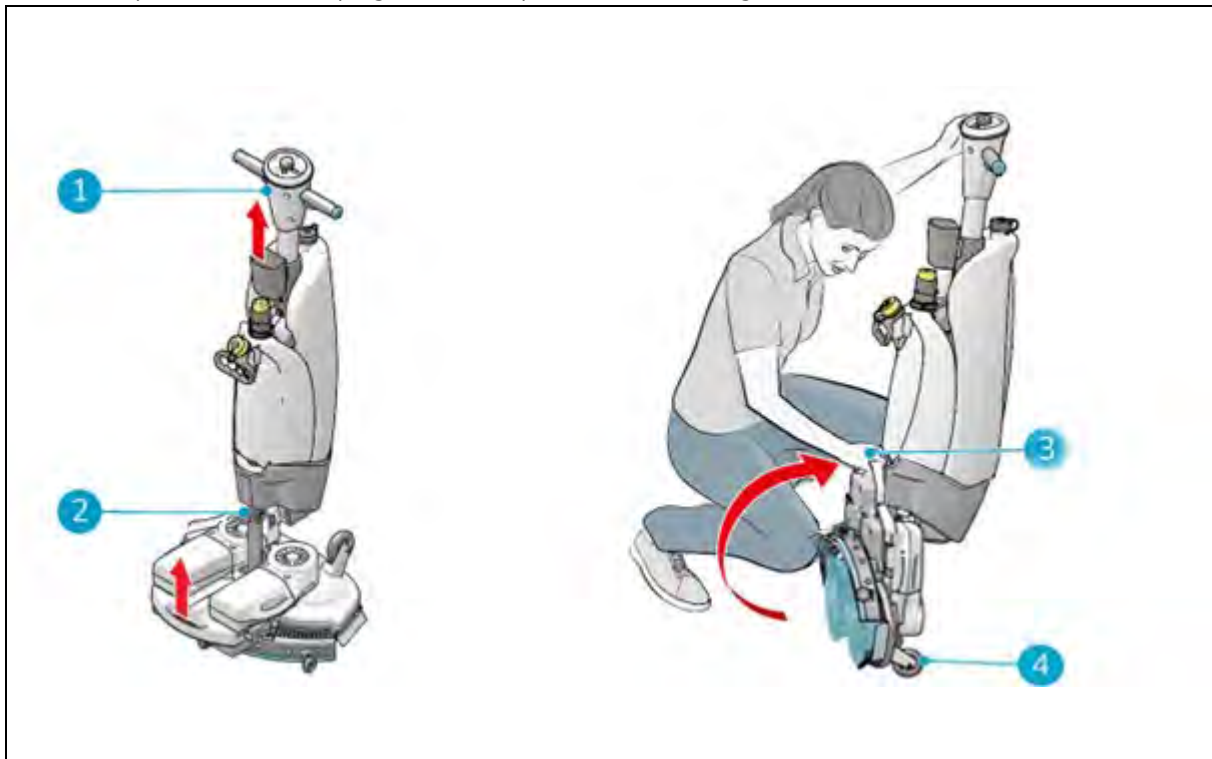

Figure 5

1. Make sure the vacuum hose (Figure 5, pos 2) is pushed back into the machine so it cannot get squeezed.
2. Crouch down and hold the handle (Figure 5, pos 1) with one hand while holding the scrub deck (Figure 5, pos 3) with your other hand.
3. Lift the scrub deck slowly until it stands upright on the front wheels (Figure 5, pos 4). Guide the body towards the scrub deck until it snaps into a resting position.



4.3 Transport outside

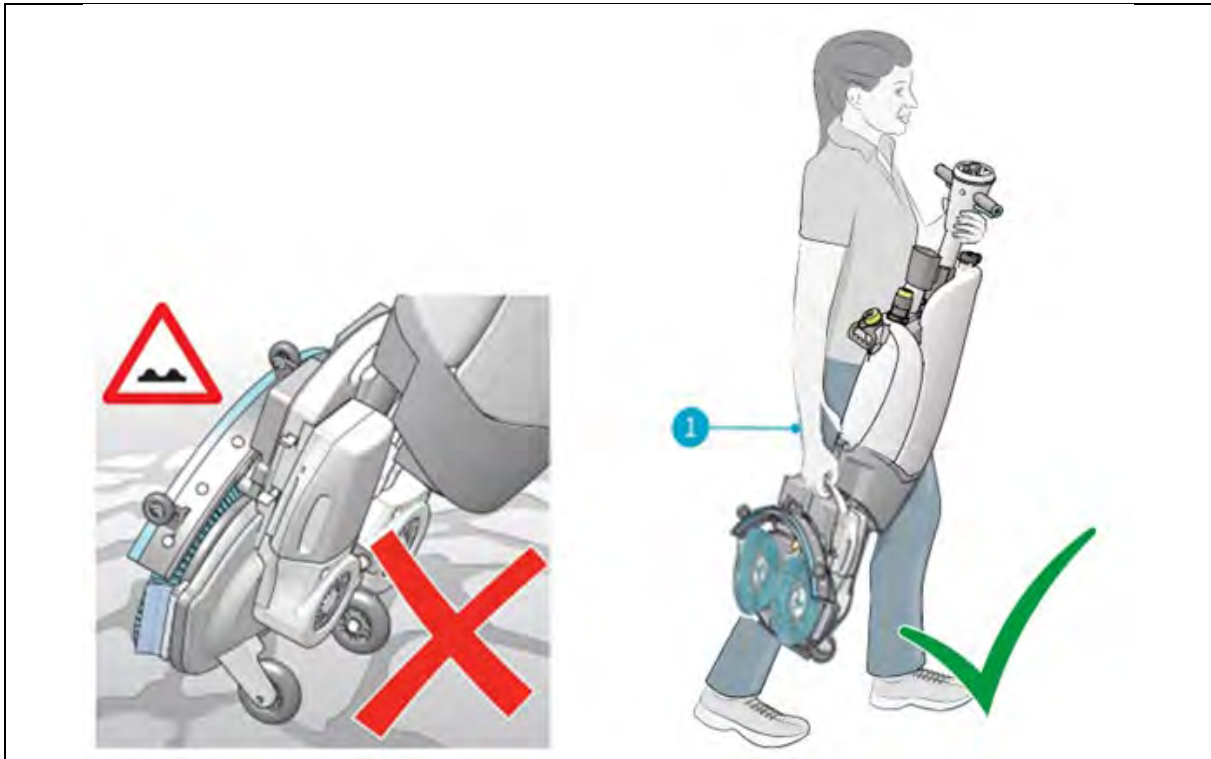

Figure 6

When outside:

1. Put the i-mop[®] XL Pro in store position, see section 4.2.
2. Carry the i-mop XL Pro with one hand while holding the handle with your other hand (Figure 6, pos. 1).



CAUTION

The transport wheels are not designed to roll over dirty surfaces, sand can cause the wheels to block. Lift the i-mop XL Pro while moving it from one building to another.



4.4 Transport in a vehicle

The preferred way to transport your i-mop® XL Pro is in an upright position and safely secured.

1. Make sure both tanks are empty.
2. Put the i-mop XL Pro in store position, see section 4.2.
3. Remove the batteries.
4. Lift the i-mop XL Pro into the vehicle. Don't forget the batteries.
5. Secure the i-mop using a tension belt or another appropriate restraint (Figure 7, pos 1).

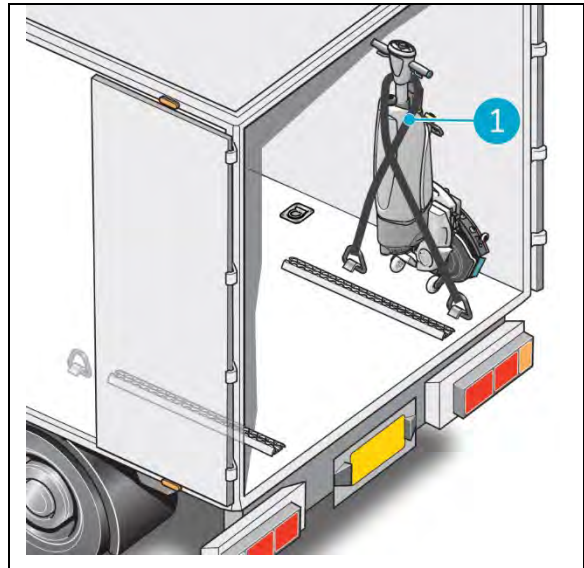

Figure 7

TIP:

The i-stand wall mount accessory can be installed in the back of a truck. It allows you to secure the i-mop and transport the i-mop in an upright position. Please contact our sales department for more information.

The i-mop XL Pro is a compact machine and fits in the trunk of your car. Before loading the i-mop XL Pro into your vehicle, make sure both tanks and battery packs are removed.

1. Put the i-mop XL Pro in store position, see section 4.2.
2. Remove the batteries and both tanks and pack them separately for transport.
3. Lift the i-mop XL Pro into your vehicle. Don't forget the tanks and batteries.
4. Prevent the i-mop XL Pro from moving around during transport by using a tension belt or another appropriate restraint.



CAUTION

The seal of the solution and recovery tank can be damaged during transport in horizontal position. Make sure you remove the tanks before loading the machine into your car. **Improper use will void the warranty.**



5 Assembly and installation

The i-mop® XL Pro does not require much assembly. Most importantly, you will have to attach the brushes and squeegee.

5.1 Unboxing

The i-mop XL Pro body is packed in a single box. The battery and charger are delivered in a separate box and can be ordered separately.

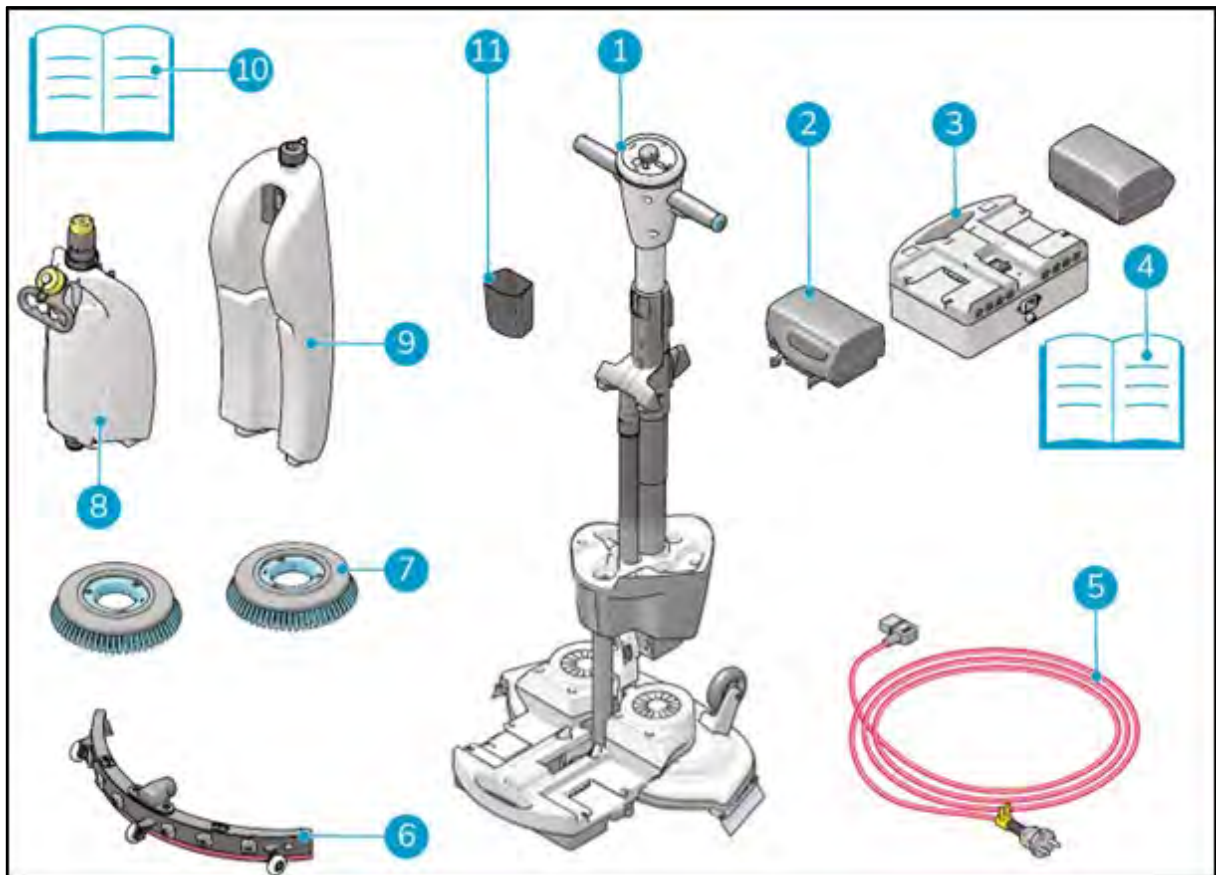

Figure 8

- | | |
|---|------------------------------|
| 1. 1x i-mop XL Pro main body | 7. 2x brushes |
| 2. 2x batteries (when ordered) | 8. 1x cleaning solution tank |
| 3. 1x battery charger (when ordered) | 9. 1x recovery tank |
| 4. 1x battery charger manual (when ordered) | 10. 1x this manual |
| 5. 1x power cord (when ordered) | 11. 1x recycle bin |
| 6. 1x squeegee assembly | |



5.2 Assembly

5.2.1 Charging the batteries

Charge the batteries according to the instructions in the battery charger manual. Make sure the battery packs are charged regularly.

5.2.2 Attaching the brushes

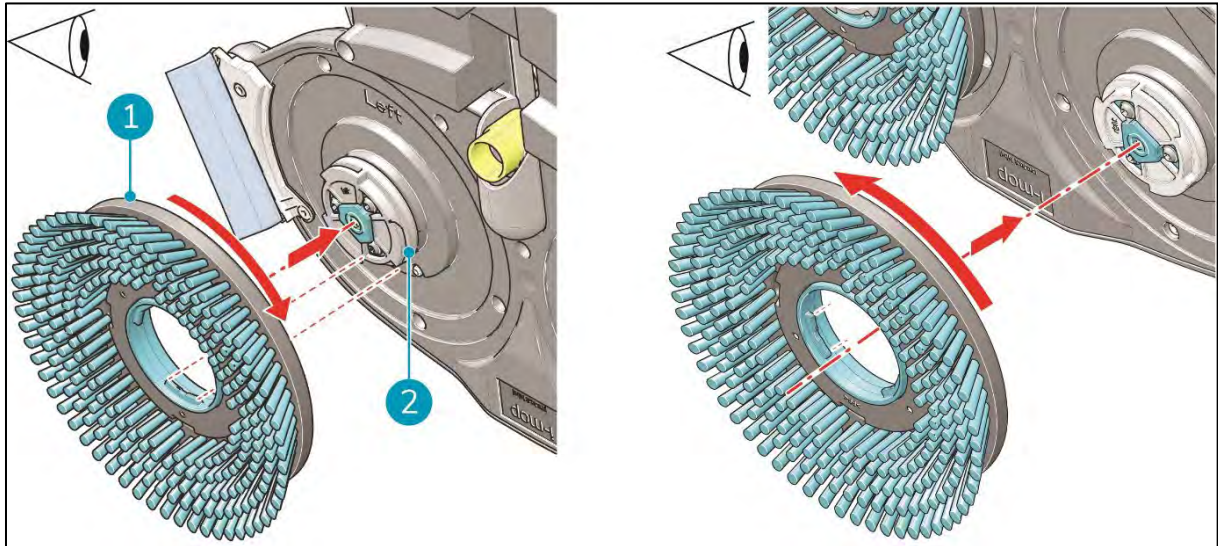

Figure 9

To attach the brushes:

1. Put the i-mop® XL Pro in store position, see section 4.2.
2. Hold the scrub deck firmly with one hand.
3. Align the left brush (Figure 9, pos. 1) with the left motor disk (Figure 9, pos. 2). Align the latches and cut-outs in the brush and motor disk.
4. Push the brush on the motor disk.
5. Turn the left brush clockwise until you see the motor disk turning. The brush is now in place.
6. Align the right brush with the right motor disk. Align the latches and cut-outs in the brush and motor disk.
7. Push the brush on the motor disk.
8. Turn the right brush anticlockwise until you see the motor disk turning. The brush is now in place.



5.2.3 Attaching the squeegee

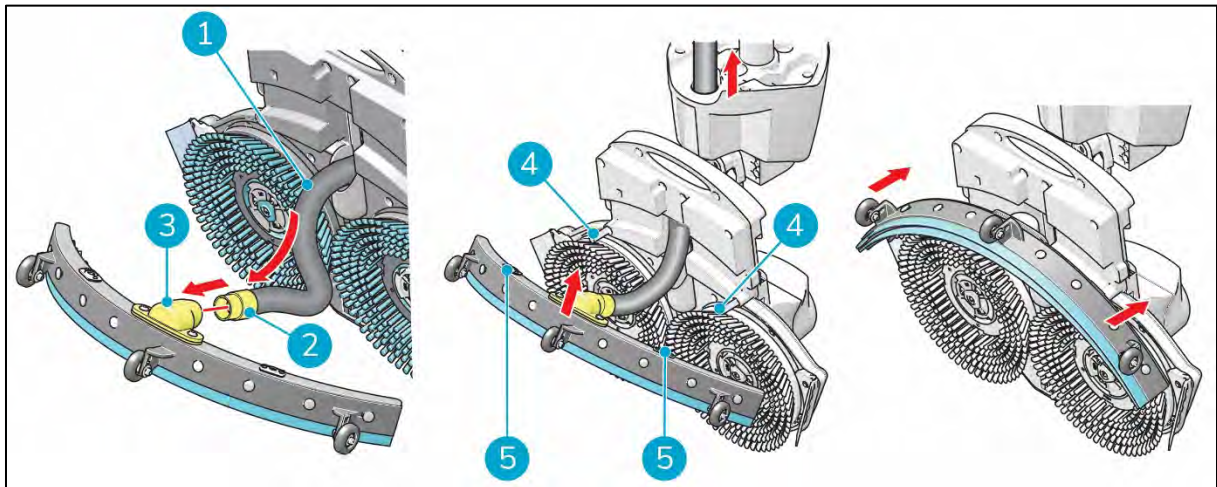

Figure 10

To attach the squeegee:

1. Take the vacuum hose (Figure 10, pos. 1).
2. Insert the hose connector (Figure 10, pos. 2) in the squeegee (Figure 10, pos. 3).
3. Twist the hose connector $\frac{1}{4}$ turn for a firm fit (Figure 10, pos. 2).
4. Carefully pull the vacuum hose back into the machine.
5. Hold the scrub deck firmly with one hand.
6. Align the pins on the scrub deck (Figure 10, pos. 4) with the holes on the squeegee (Figure 10, pos. 5).
7. Push the left side of the squeegee in place.
8. Push the right side of the squeegee in place.

5.2.4 Installing the recovery tank

1. Put the bottom of the recovery tank (Figure 11, pos. 1) on the front of the i-mop[®] XL Pro (Figure 11, pos. 3).
2. Push the top of the tank into place until you hear a 'click' sound, the magnet (Figure 11, pos. 2) will lock the recovery tank into place.

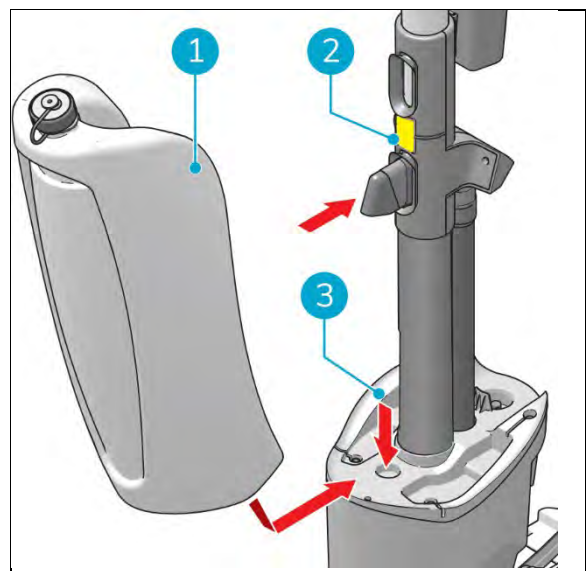

Figure 11



5.2.5 Installing the cleaning solution tank

1. Put the i-mop® XL Pro in store position, see section 4.2.
2. Put the cleaning solution tank (Figure 12, pos. 1) on the i-mop XL Pro with the valve first.
3. Press the tank downward on the nipple to open the valve seal.
4. Push the tank forward into place until you hear a 'click'.

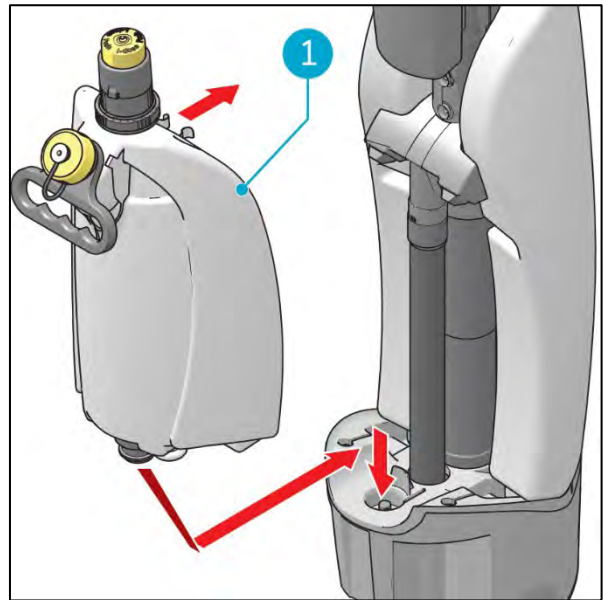

Figure 12

5.2.6 Attaching the recycle bin

1. Slide the rear of the recycle bin (Figure 13, pos. 1) into the recycle bin slot.

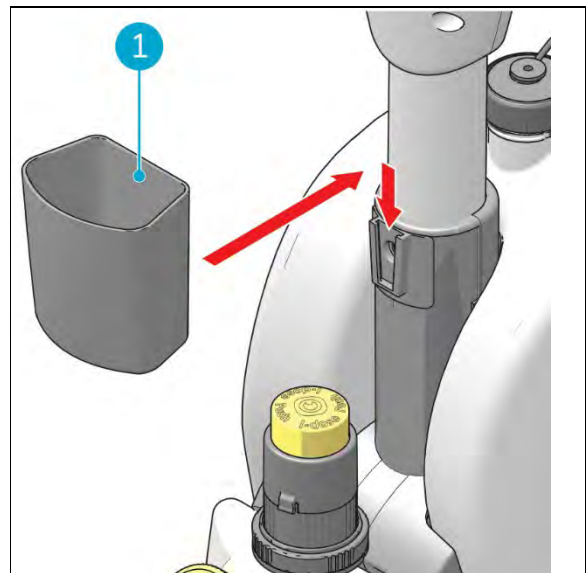

Figure 13



5.2.7 Installing the drive support

2. Place the i-mop® XL Plus in the active position with the front of the main body leaning against a stable wall.
3. If present, remove the batteries.
4. Remove the nuts (Figure 14, pos. 1) from the bolts (Figure 14, pos. 2).
5. Remove the bolts.
6. The bracket can now be removed and replaced. The preassembled blue bracket is 100 mm and the grey bracket is 90 mm.
The blue and grey bracket are interchangeable.
7. Replace the bolts and tighten the nuts.

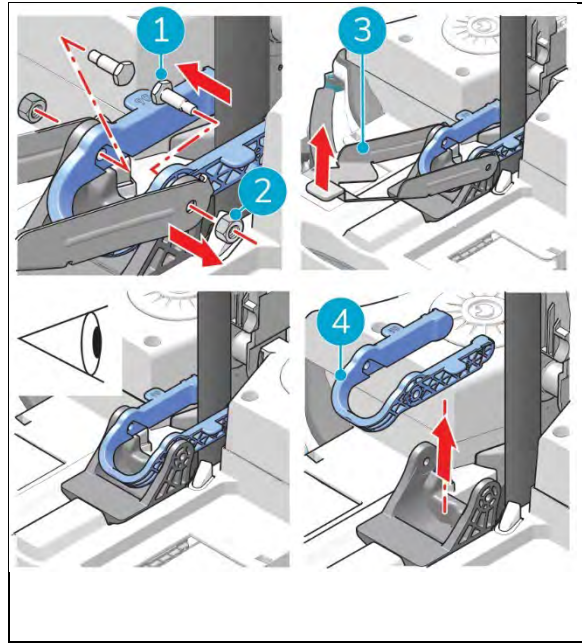

Figure 14



6 Operation

6.1 Before you start

Check the brushes and squeegee for wear and tear, see section 7 for maintenance.

6.1.1 Inserting the batteries



CAUTION

Only use i-power® batteries specifically designed for use in i-mop® devices.

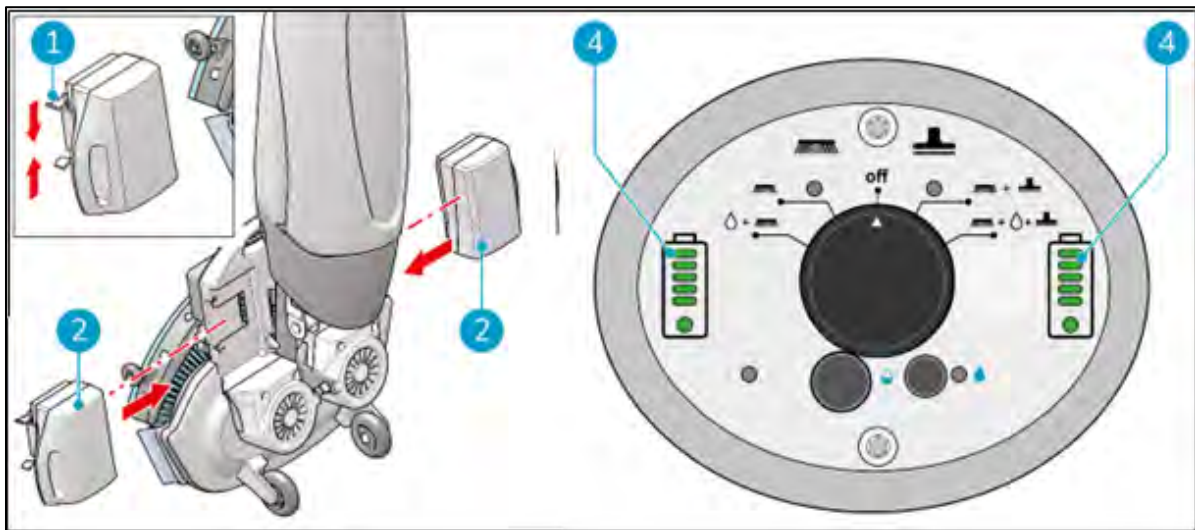

Figure 15

1. Push the blue coded battery (Figure 15, pos. 2) in the blue battery slot. A click indicates the battery is locked in place (Figure 15, pos. 1).
2. Push the grey coded battery in the grey battery slot. A click indicates that the battery is locked in place.
3. During operation, the battery indicators (Figure 15, pos. 4) on the control panel show the amount of power left.

TIP:

It is not recommended to use the batteries when charged below 40% (2 marks).



6.1.2 Filling the cleaning solution tank

1. Remove the yellow cap (Figure 16, pos. 1).
2. Pour in a maximum of 1 gal / 4 L of water (Figure 16, pos. 2).
3. But back the yellow cap (Figure 16, pos. 1) and make sure it seals tightly.

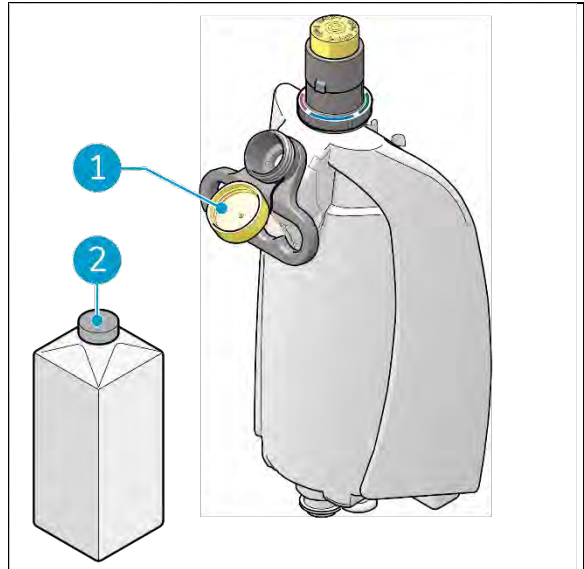

Figure 16

4. If applicable, remove the old i-dose pod and remove the cap (Figure 17, pos. 1).
5. Place the desired i-dose pod (Figure 17, pos. 2) in the i-dose injector.
6. But back the cap (Figure 17, pos. 1).
7. Close the i-dose top (Figure 17, pos. 4).
8. Press the i-dose injector button (Figure 16, pos. 5) to dispense the contents of the i-dose pod.
9. Turn the indicator ring so that the color corresponding to the i-dose pod is facing towards you (Figure 16, pos. 3).

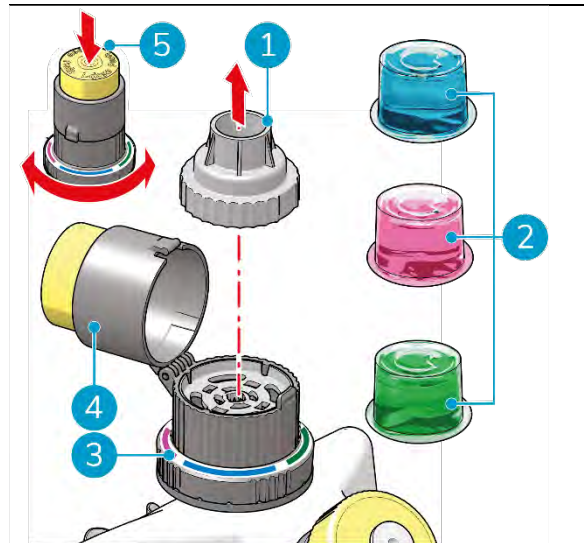

Figure 17



6.2 Operation procedure

6.2.1 Walking to the job site



Figure 18

To move the i-mop[®] XL Pro from one location to another one in a building:

1. Put the i-mop XL Pro in store position, see section 4.2).
2. Hold the handle with one hand (Figure 18, pos. 1).
3. Walk slowly and pay extra attention if you pull the i-mop XL Pro over obstacles.
4. To lift the i-mop XL Pro over obstacles, always use two hands.
 - Hold the handle with one hand.
 - Lift the scrub deck with the other hand.



6.2.2 At the job site

1. Crouch down while holding the scrub deck firmly with one hand (Figure 19, pos. 2).
2. Push the handle forward with your other hand (Figure 19, pos. 1).
3. Bring the scrub deck slowly down to the floor.

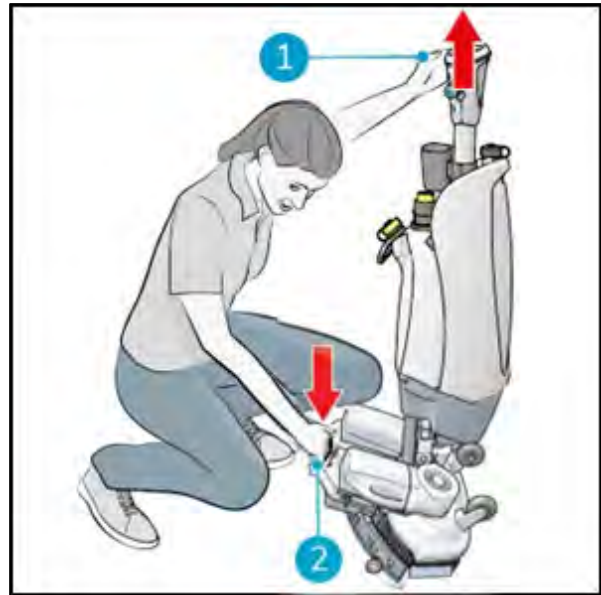

Figure 19



WARNING

Never push down the scrub deck with your foot.

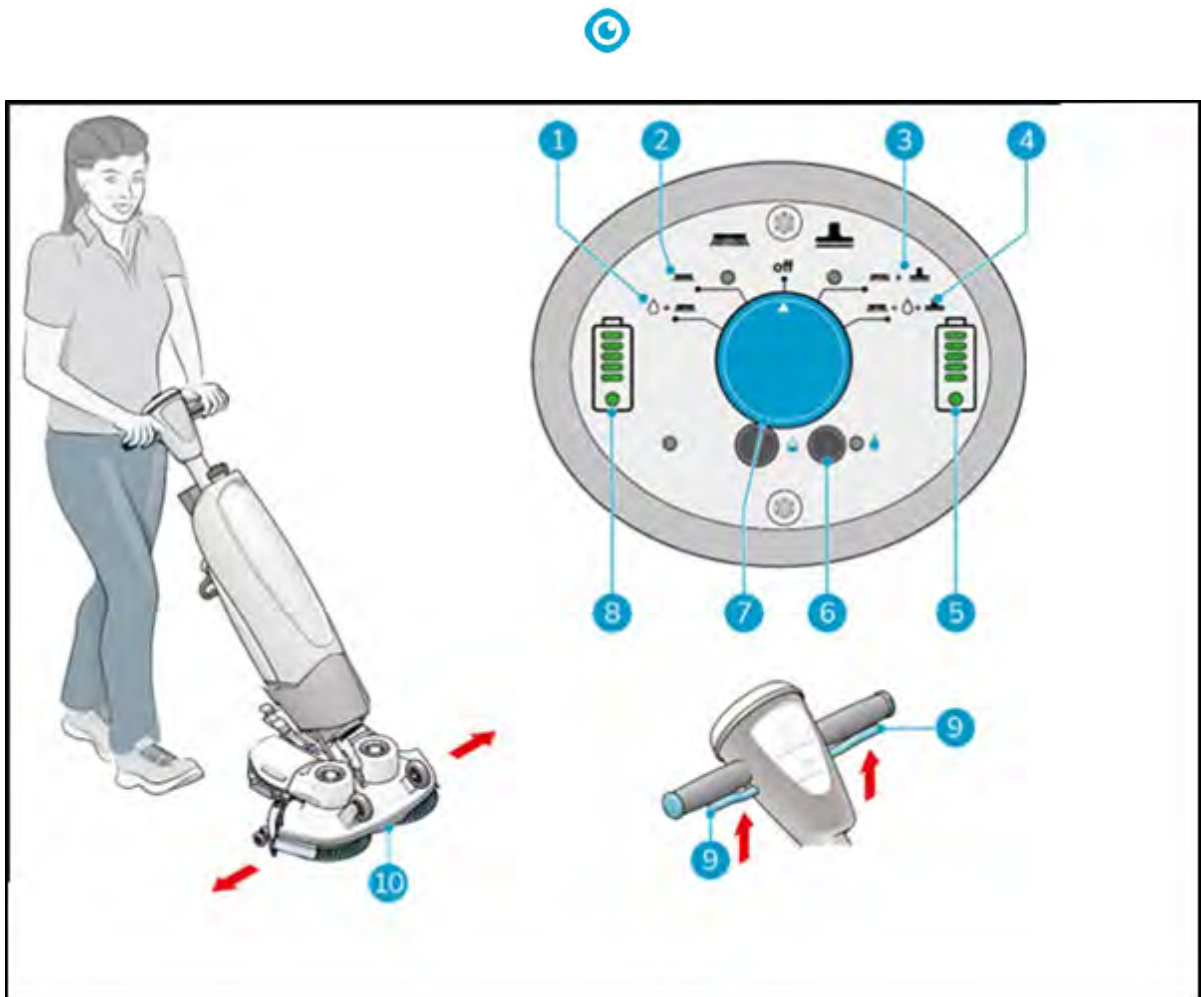

Figure 20

4. Stand behind the i-mop® XL Pro. Choose your cleaning mode via the main switch (Figure 20, pos. 7). This will also turn on the i-mop XL Pro.
 - MODE 1: Brush + water/cleaning solution (Figure 20, pos. 1).
 - MODE 2: Brush only (Figure 20, pos. 2).
 - MODE 3: Brush + vacuum (Figure 20, pos. 3).
 - MODE 4: Brush + water/cleaning solution + vacuum (Figure 20, pos. 4).
5. Hold the handle with both hands.
6. Squeeze the trigger on the handle (Figure 20, pos. 9).
7. Once the trigger is squeezed the i-mop XL Pro will move forward.
8. Walk behind the i-mop XL Pro.
9. Steer by gently turning the handle left or right to move the scrub deck (Figure 20, pos. 10).
10. Releasing the trigger (Figure 20, pos. 9) will immediately stop the i-mop XL Pro. The vacuum motor will stop after 3 seconds.



TIP: Learn to swivel

Operating the i-mop® XL Pro is very intuitive and like steering a bicycle. The i-mop XL Pro is designed to move forward. To turn, stop walking and use your inside hand (the hand in the direction you want to go to) to turn the handle. The i-mop XL Pro can swivel 360 degrees making it possible to reverse direction.



WARNING

Do not operate the i-mop XL Pro at more than an arm's length. Operating below a 45-degree angle can cause water to run into the vacuum engine.

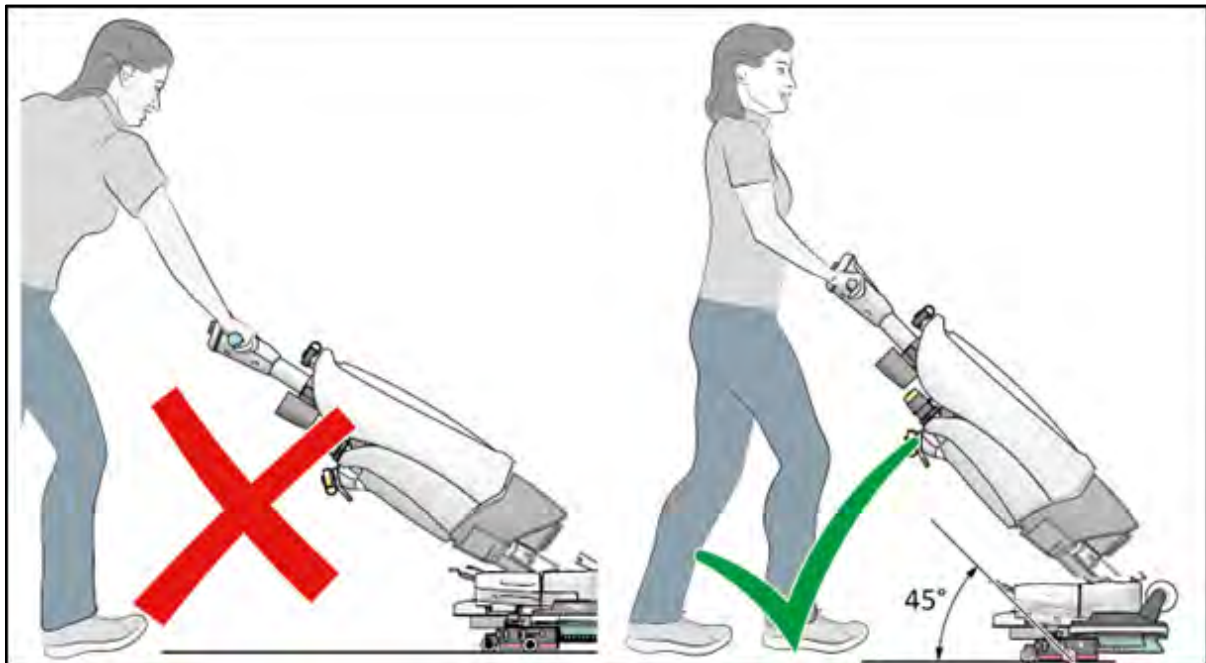

Figure 21



6.2.3 Drive support



WARNING

Do not park the i-mop® XL Pro on the drive support, the device can fall down sideways.

1. Push the edge of the drive support down (Figure 22, pos. 1) to bring the drive support up .
2. Lean the main body of the i-mop XL Pro against the drive support.
3. Use the i-mop XL Pro as normal.
4. To deactivate the drive support push the entire bracket down.

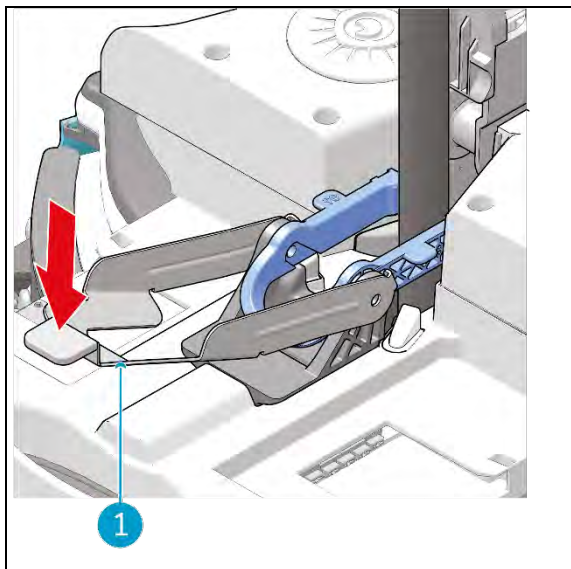

Figure 22

6.2.4 Park support



WARNING

Do not store the i-mop XL Pro in park position. To avoid wear on the brushes, an alarm will sound and lights will start blinking when the i-mop is in park position for over 10 minutes.

1. Lift the park support up to activate.
2. Let the main body of the i-mop XL Pro rest against the park support.
3. Park the i-mop XL Pro for less than 10 minutes.
4. After 10 minutes the device will automatically be disabled. An alarm will sound and lights will start blinking.
5. Lift the deck to stop the alarm and restart the i-mop.
6. To deactivate the park support push the entire park support down.

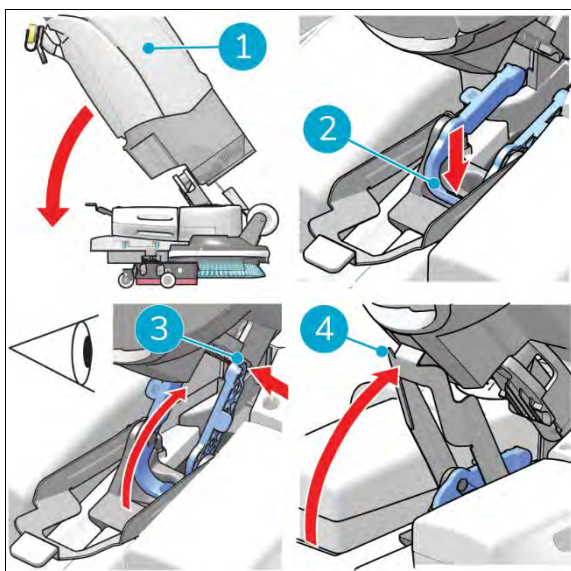

Figure 23



6.2.5 Lifter kit



WARNING

Walk slowly and pay extra attention when the lifter kit is activated. The floor remains wet. Make sure to mark the job site using a wet floor marker.

Activating the lifter kit will lift the squeegee up, to give detergents some dwell time.

1. Put the i-mop® XL Pro in store position, see section 4.2.
2. Turn the lever (Figure 24, pos. 2) 180° following the arrow .
3. Pull the lifter kit down. The yellow part shows (Figure 24, pos. 1).
4. Turn the lever back 180° to lock it in lift position.
5. Use the device as normal. Be careful the floor will remain wet.

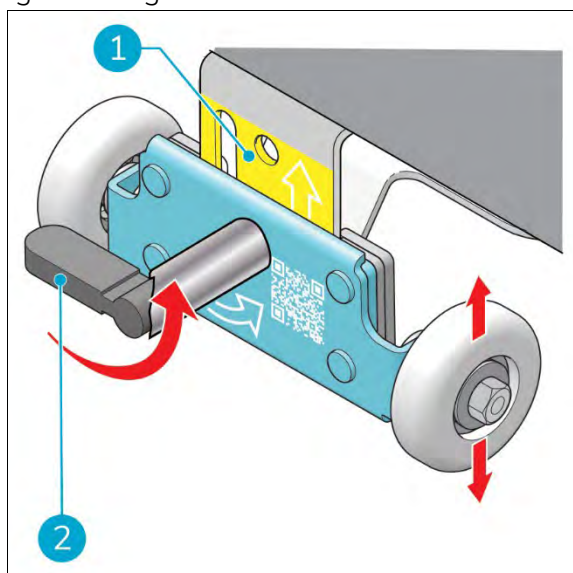

Figure 24

Make sure to end cleaning of the jobsite with the lifter kit deactivated.

1. To deactivate turn the lever 180°. The weight of the machine will push the lifter kit in.
2. Turn the lever back 180° to lock it in normal position.

6.2.6 ECO mode

The ECO mode will use 40% less cleaning solution.

1. Turn on the ECO mode by pushing the ECO button (Figure 25, pos. 1).
2. Turn off ECO mode by pushing the ECO mode again.

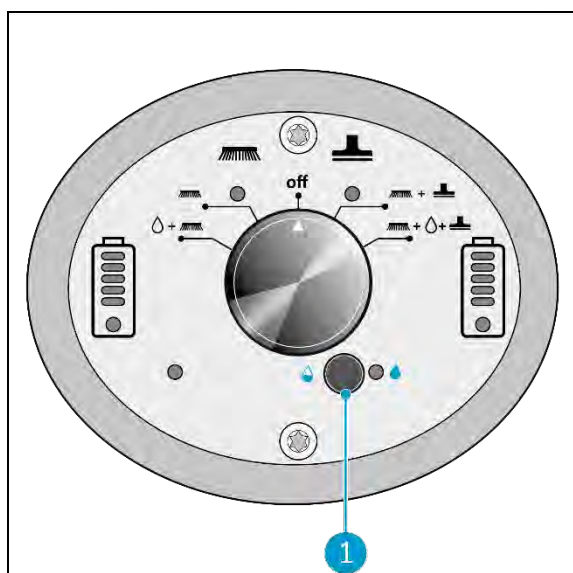

Figure 25



6.2.7 Water level warning indicator

The water level warning indicator is situated on the control panel (Figure 26, pos. 1). When the recovery tank needs to be replaced, the indicator light will turn on and the machine will be shut off.

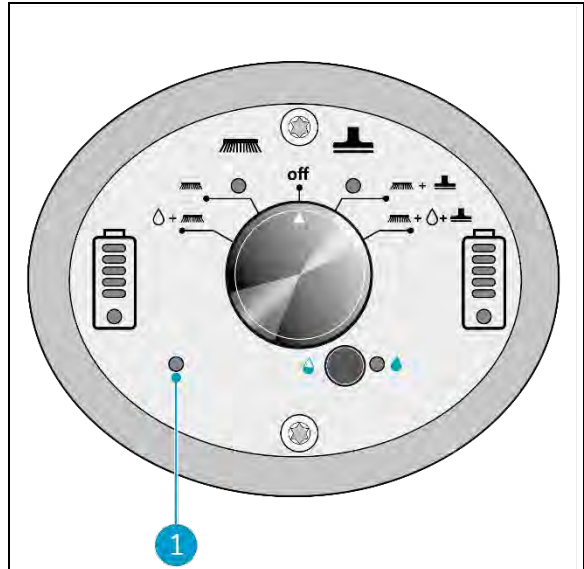

Figure 26

6.2.8 Turning off the i-mop® XL pro

1. Use the i-mop XL Pro main switch (Figure 27, pos. 1) and choose MODE 3 Brush + Dry vacuum (Figure 27, pos. 2).
2. Operate it about 15-20 feet / 4-6 meter farther to vacuum remaining cleaning solution up.
3. Then set the main switch to the OFF position.

Note that the vacuum motor will continue to run for approximately 3 more seconds.

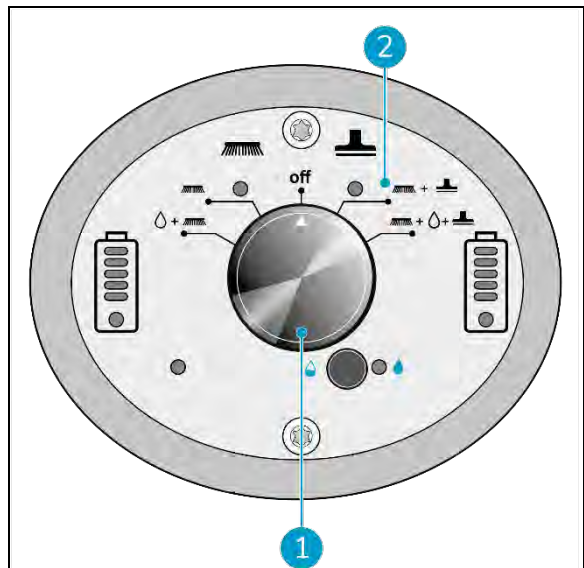

Figure 27

6.2.9 Emptying tanks

Dispose of water or cleaning solution from both tanks in an appropriate drain. Even though the recovery tank is bigger, empty it each time the cleaning solution tank is filled.



WARNING

Please observe the local provisions regarding solution disposal related to wastewater treatment.



6.3 Cleaning and storage

6.3.1 Flushing the system

Be sure to flush the tanks out completely to discard any remaining solution in the lines and valves:

1. Refill the solution tank with 2 to 4 cups / 0.5 to 1 liter of clean water.
2. Use the i-mop XL Pro main switch (Figure 28, pos. 1) and choose MODE 4 Brush + Water/Cleaning solution + Dry vacuum (Figure 28, pos. 2).

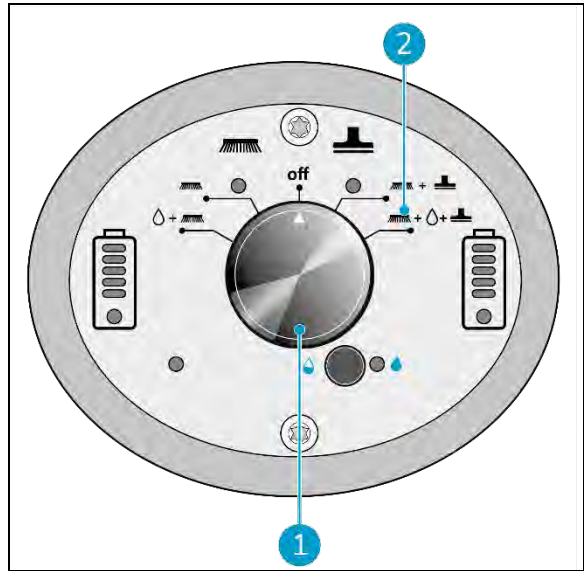

Figure 28



6.3.2 the tanks

1. Dispose of water or cleaning solution from both tanks in an appropriate drain.
2. To clean the recovery tank thoroughly:
 - Partially fill the tank with fresh water and hold it horizontally with the holes facing up.
 - Tilt the tank repeatedly, thoroughly rinsing all the dirt and debris out from the tank.
3. To clean the solution tank, follow the same procedure.

TIP: Dry the tanks

Slightly open both tank caps before storage to allow the tanks to dry.

6.3.3 Removing battery packs

1. Put the i-mop® XL Pro in store position, see section 4.2.
2. Hold the i-mop XL Pro by the scrub deck to stabilize.
3. While pressing both plastic pins inwards (Figure 29, pos. 1), pull each battery pack away (Figure 29, pos. 2).
4. When the i-mop XL Pro isn't used regularly, store the charged battery packs in a dry, clean place.
5. Make sure the battery packs are charged monthly.

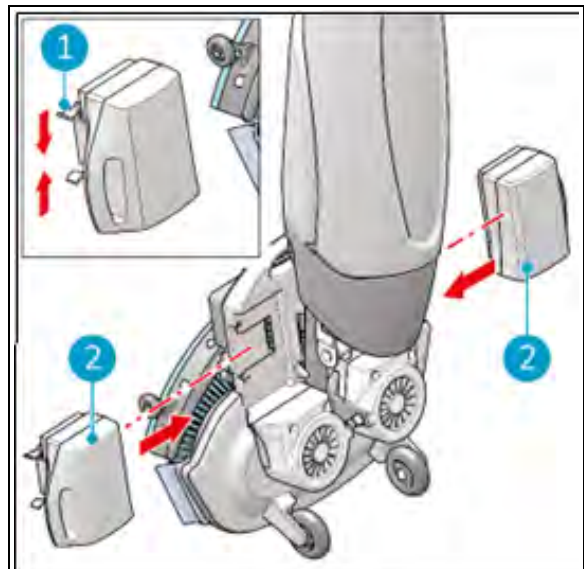

Figure 29

6.3.4 Checking the brushes and squeegee

1. Check to see if both brushes are clean and intact, see section 7.1 for removal instructions.
 - Clean them under fresh water or replace them if necessary.
 - Replace brushes if the yellow wear indicator is the same height as other bristles.
2. Check to see if the squeegee is clean and intact, see section 7.2.1 for removal instructions.
 - Clean it with fresh water and wipe it with a clean, damp cloth.
 - Replace the squeegee blades when necessary.



6.3.5 Store in an upright position

1. Please ensure that the i-mop® XL Pro is stored in a place where nobody can bump into it.
2. Put the i-mop XL Pro in store position, see section 4.2.
3. Store the i-mop XL Pro close to a wall (Figure 30, pos. 1) with the handle pointing facing away from the wall and the brushes towards the wall.

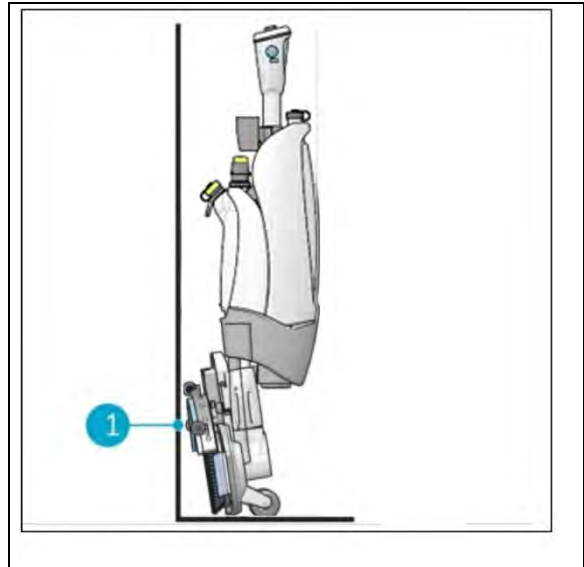

Figure 30



7 Maintenance



CAUTION

Remove the battery before executing any cleaning or maintenance task.



CAUTION

Always keep the body of the i-mop® XL Pro in an upright position when replacing the brushes or the squeegee.

7.1 Brush replacement

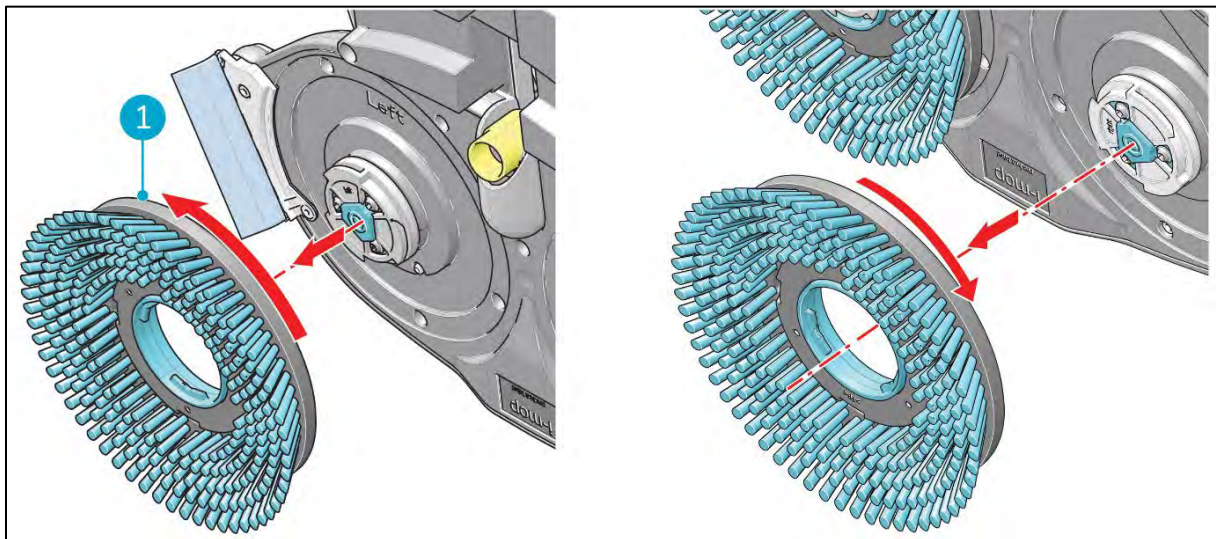

Figure 31

The brushes are attached to the scrub deck with a bayonet fitting.

1. Put the i-mop XL Pro in store position, see section 4.2.
2. Hold the scrub deck firmly with one hand.
3. Using your other hand to turn the left brush (Figure 31, pos. 1) anticlockwise until you feel resistance or see the motor disk turning as well.
4. Pull the brush towards you, off the motor disk.
5. Turn the right brush clockwise until you feel resistance or see the motor disk turning as well.
6. Pull the brush towards you, off the motor disk.
7. Visually inspect the motor disks.
8. Clean the i-mop XL Pro scrub deck with a clean, dry cloth before you install the brushes.



7.2 Squeegee replacement

The squeegee blades come in pairs and wear out over time. When you notice the floor is no longer being dried properly, replace the squeegee blades.

7.2.1 Detaching the squeegee

1. Put the i-mop® XL Pro in store position, see section 4.2.
2. Hold the scrub deck firmly with one hand.
3. Pull on the left side of the squeegee to remove it (Figure 32, pos. 1).
4. Pull on the right side of the squeegee to remove it (Figure 32, pos. 2).
5. Remove the vacuum hose from the squeegee by twisting the hose.

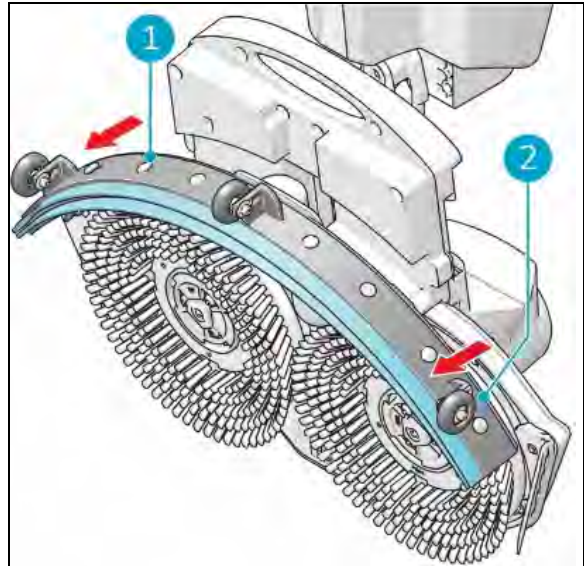

Figure 32

7.2.2 Flipping/replacing the squeegee blade

1. Unscrew the 8 plastic nuts on the back.
2. Take off the squeegee rear plate.
3. Once the plastic part is removed, you can easily take off the rear rubber blade.
4. Push the 8 screws through the front blade in order to remove the squeegee front plate.
5. Take off the rear rubber blade.
6. Inspect the front and rear rubber blades:
 - The first time: flip the blades so the top of the blade is now facing the floor. Push the front plate screws through the holes.
 - The second time: attach a new set of blades. Push the front plate screws through the holes.



CAUTION

The special squeegee blades that contain small arrow-like shapes cannot be switched. These need to be replaced every time.

7. Put back the plastic rear plate.
8. Screw the 8 plastic nuts on the back.



7.2.3 Attaching the squeegee

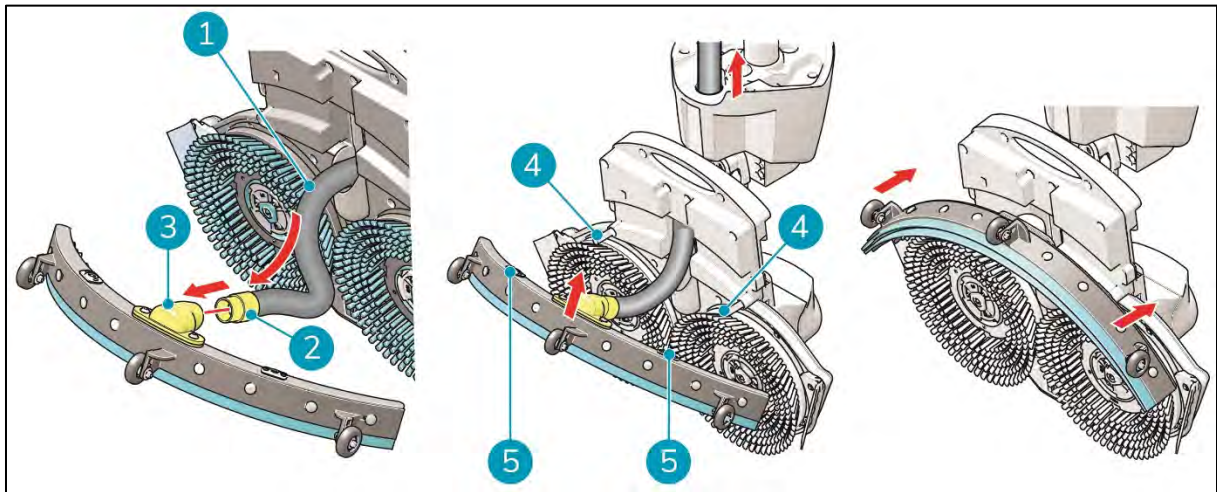

Figure 33

To attach the squeegee:

1. Take the vacuum hose (Figure 33, pos. 1).
2. Insert the hose connector (Figure 33, pos. 2) in the squeegee (Figure 33, pos. 3).
3. Twist the hose connector 1/4 turn for a firm fit (Figure 33, pos. 2).
4. Carefully pull the vacuum hose back into the machine.
5. Hold the scrub deck firmly with one hand.
6. Align the pins on the scrub deck (Figure 33, pos. 4) with the holes on the squeegee (Figure 33, pos. 5).
7. Push the left side of the squeegee in place.
8. Push the right side of the squeegee in place.

7.3 Replacing the vacuum hose

1. Detach the squeegee as described in 7.2.1.
2. Remove the solution tank. You can see where the vacuum hose is connected at the i-mop® XL Pro handle.
3. Hold the scrub deck firmly with one hand.
4. Detach the vacuum hose by twisting the connector 1/4 turn anticlockwise.
5. Now you can carefully pull the vacuum hose from the top of the machine.
6. Guide the new vacuum hose via the opening to the hose connector located at the i-mop XL Pro handle.
7. Connect the top to the hose connector by twisting it clockwise 1/4 turn until they have lined up.
8. Reinstall the squeegee.



7.4 Recommended additional cleaning

Clean the exterior of the i-mop® XL Pro weekly with a non-abrasive, non-solvent cleaner or a clean, damp cloth. To clean the scrub deck, remove the brushes.

7.5 Recommended service time

Service must be done by one of our service partners. The first service is recommended after 200 hours. It is recommended to schedule a full service every 500 hours.

Check the operating hours on a regular basis in i-link, via: ilink.i-teamglobal.com. For more information see the i-link manual.

7.6 Accessories

The i-mop XL Pro can be equipped with different brushes and polishing pads. The use of these accessories is only allowed by experienced and trained operators as some polishing pads can be abrasive and can cause damage to the floor surface when applied incorrectly. For more information please contact our sales department, or the partner who provided the i-mop XL Pro.



8 Troubleshooting

Problem	Cause	Solution
No power	No batteries	Insert batteries
	Empty batteries	Charge batteries
	Batteries incorrectly placed	Remove and reinstall batteries
Insufficient/no water flow	Wrong program	Check the operating mode on the control panel
	Eco mode on	Check the ECO mode light on the control panel
	Empty tank	Fill the tank
	Tank incorrectly placed	The tank valve must be clicked on the nipple to open the seal, replace the tank
	Filter blocked	Ensure the solution tank has no dirt particles and the filter is clean
	Blocked water pipe	Request for service
Poor water recovery	Squeegee opening blocked	Remove the pipe and clean the squeegee opening
	Tears in squeegee blades	Replace squeegee blades
	Filter blocked	Check the yellow filter and clean if necessary
	Vacuum hose blocked	Check and remove blockage
	Vacuum pump not running	Request for service
Leakage	Tanks incorrectly placed	Check and reattach fluid tanks
	Tear in vacuum hose	Replace vacuum hose or request for service
Battery not charging	Battery is at end of life	Replace battery

8.1 Report problem via i-link®

1. Scan the QR code on the device with a phone or tablet.
2. The i-link QR landing page will open.
3. Click “Report a problem” and report the problem.



9 Decommissioning and disposal



ATTENTION

It is the responsibility of the i-mop[®] XL Pro owner to dispose of the product responsibly.

After decommissioning, the i-mop XL Pro still contains valuable resources and needs to be disposed of according to your local laws and regulations regarding recycling of electrical equipment.



Before disposal please:

1. Flush the machine, see section 6.3.1.
2. Remove the batteries for separate disposal, see section 6.3.3.

TIP:

Alternatively, keep the batteries for use in another piece of i-team equipment.

3. Remove all loose components like brushes, tanks and squeegee.
4. Dispose all items according to your local laws and regulations.



10 Attachments

10.1 CE Certificate

C E R T I F I C A T E		 TÜVRheinland®
of Conformity		
EC Council Directive 2014/30/EU Electromagnetic Compatibility		
Registration No.:	AE 50408406 0001	
Report No.:	50127657 001	
Holder:	Future Cleaning Technologies (FCT) B.V Hoppenkuil 27A 5626 DD Eindhoven Netherlands	
Product:	Floor Cleaning Machine (i-mop)	
Identification:	XL XXL Serial No.: n.a. Remark : Refer to test report 50127657 001 for details.	
Tested acc. to:	EN 55014-1:2006+A1+A2 EN 55014-1:2017 EN 55014-2:1997+A1+A2 EN 55014-2:2015	
<p>This certificate of conformity is based on an evaluation of a sample of the above mentioned product. Technical Report and documentation are at the Licence Holder's disposal. This is to certify that the tested sample is in conformity with all provisions of Annex I of Council Directive 2014/30/EU. This certificate does not imply assessment of the production of the product and does not permit the use of a TÜV Rheinland mark of conformity. The holder of the certificate is authorized to use this certificate in connection with the EC declaration of conformity according to the a.m. Directive</p>		
Date <u>20.06.2018</u>	Certification Body  Dono Zhou 	
TÜV Rheinland LGA Products GmbH - Tillystraße 2 - 90431 Nürnberg		
 The CE marking may only be used if all relevant and effective EC Directives are complied with. 		



10.2 Specifications

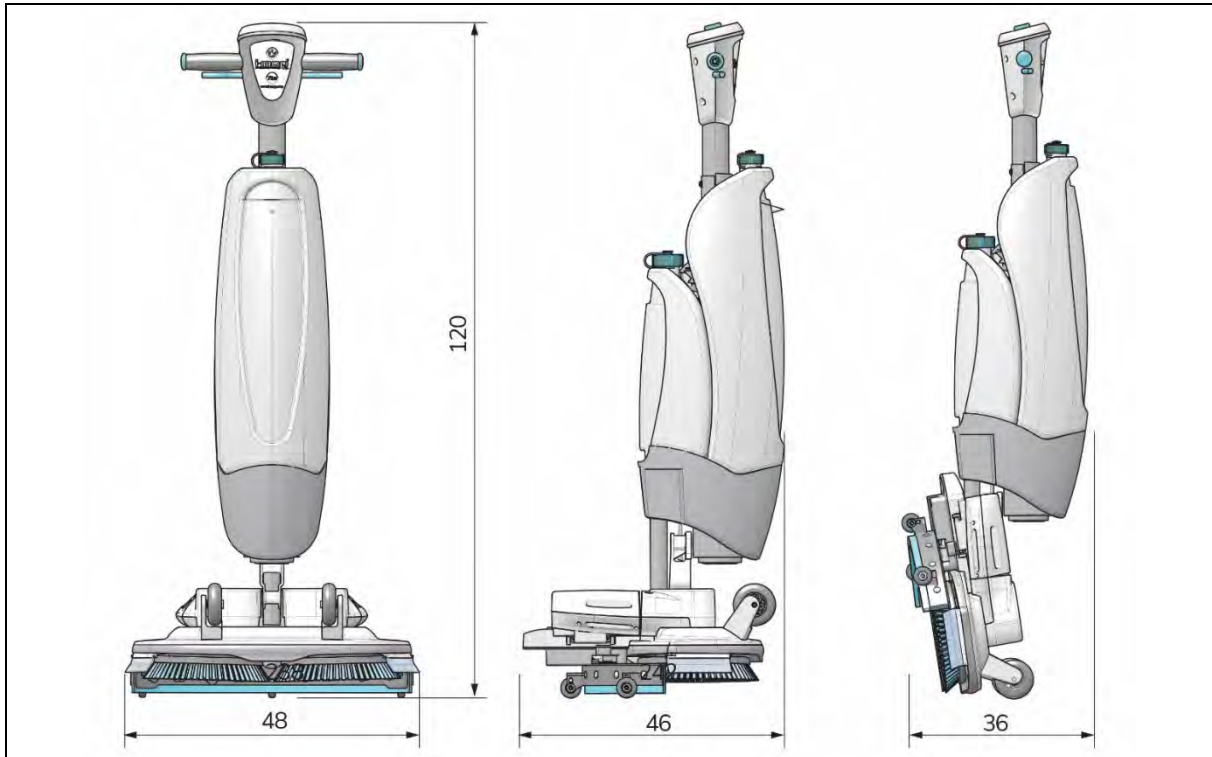

Product size:	120 x 48 x 46 cm
Product size in store position:	120 x 48 x 36 cm
Weight (including batteries):	22.5 kg
Li-on battery:	DC (25.2V, 14Ah, 353Wh)
Battery capacity:	2 batteries
Operation time of batteries:	90 min
Brush pressure:	31.5 gr/cm ²
Brush speed:	350 RPM
Detergent tank capacity:	4 L
Recovery tank capacity:	6 L / 4 L recommended max
Vibration:	Amplitude (mm): <0.4442 Velocity (m/s): <0.008 Acceleration (m/s ²): 0.943
Noise level (1m):	64.9 Db
Theoretical performance:	Up to 1800 m ² per hour
Practical performance:	1000 - 1300 m ² per hour
Scrub deck anti-corrosion coating:	YES
Castor wheels:	YES
Power cut off at store position:	YES
Angle power cut off:	YES < 32°
Floating ball for recovery tank:	YES
Hour counter:	YES via i-link



10.3 The i-Story

It's not just about cleaning machines.

It's about the well-being of people and the planet.

We are stoked about cleaning, thrilled about sustainability and wholeheartedly dedicated to keep on innovating.

We believe effective cleaning is more than Just' the removal of soil. It means ensuring the health and safety of people, while making the job easier, simpler, more efficient and even fun. It means consistent results all over the world, while protecting the world. And it means creating partnerships to grow our global force for better cleaning. After all, it takes a team.

The i-team.

Made Blue

By operating i-mops, your partners, clients and users lower the water footprint whilst contributing positively to the availability of water in the world. Every day an i-mop is turned on, Made Blue simultaneously ensures someone else on the planet gets access to clean water. For every liter that the i-mop uses in operations, the i-team and Made Blue mirror clean drinking water in a developing country. The planet is a beautiful place with over 7 billion people. Humans need water to live, breathe, and enjoy their lives. Worldwide 2,7 billion people suffer from a shortage of drinking water. For 780 million people this situation is permanent each year 3,5 million people die because of this. That's why Made Blue invests in projects in developing countries. We are a proud partner of Made Blue. Made Blue mirrors the water used by i-team to create clean water in developing countries. 1 liter for 1 liter.



MADE BLUE



Access to clean water for All.





i-team Professional b.v.

Hoppenkuil 27b, 5626 DD Eindhoven, The Netherlands

Telephone: +31402662400

Email: hello@i-teamglobal.com

Internet: www.i-teamglobal.com

